

Parts:

2 - Front Strut Extensions 8 - SAE Flat Washers
4 - 10x1.5x90mm Bolts 4 - 10mm Nuts

Sierra/Silverado 1500 2WD/4WD 2.5" Level Lift Kit

PRE-INSTALLATION

Professional installation by a certified technician is strongly recommended.

Not responsible for altered products. No claims are made regarding any lifting devices. Any and all claims implied in this document excluded.

NOTES:

This kit is designed to fit 2007 & up GM vehicles with fabricated, aluminum, and cast steel lower control arms. The following instructions assume the use of factory wheels with size 285/70/17 tires. The use of wider tires will require trimming and offset wheels.

REQUIRED TOOLS:

21mm Wrench	18mm Wrench	17mm Wrench	15mm Wrench
15mm Socket	7/32 Allen Wrench	Flat Screwdriver	Hammer

INSTALLATION INSTRUCTIONS

- STEP 1:** Jack up front of vehicle so that front wheels are off the ground. Support vehicle with jack stands.
- STEP 2:** Remove front wheels. (21mm deep well socket)
- STEP 3:** Loosen upper strut bolts, but leave nuts in place. (18mm wrench)
- STEP 4:** Support knuckle with jack stand and remove upper ball joint nut. (18mm wrench) Hit the knuckle with hammer on the side to separate the ball joint from the knuckle, but don't let the knuckle to pull out so far that the shaft pulls out of the differential.
- STEP 5:** Remove nut from the steering linkage. (21mm wrench) Hit the side of the knuckle with hammer where the steering linkage is connected and remove from knuckle. Push the linkage forward until out of the way. (Save factory hardware)
- STEP 6:** Remove sway bar nut and bushings. (15mm wrench and 15mm socket - Save factory hardware)
- STEP 7:** Remove bolts from bottom strut mount. (15mm wrench)
- STEP 8:** Remove bolt clips from bottom of strut. (Flat Screwdriver)
- STEP 9:** Remove upper strut nuts and remove strut from vehicle.
- STEP 10:** Install spacer plate on top of strut and reinstall in vehicle - hand tighten only.
- STEP 11:** Insert strut extension under the lower strut mount, lining up the holes.
- STEP 12:** For steel or aluminum control arms, install new 90 mm bolts from the top down with provided washers and nuts. Move knuckle to the side if you need room to install bolt closest to axle shaft. Tighten to 30-35 ft/lbs. - **Do not over-tighten!** (Bolt:17mm wrench, Nut:16mm wrench)
- STEP 13:** Tighten upper strut nuts and torque to factory specs. (18mm wrench)
- STEP 14:** Raise lower control arm, connect upper ball joint on upper control arm to spindle and torque to factory specs. (18mm wrench) Use 7/32 allen wrench to keep ball joint from turning while tightening,
- STEP 15:** Reinstall steering linkage nut. (21mm wrench) Use 10mm wrench to hold bottom of tie rod to keep ball joint from turning.
- STEP 16:** Repeat steps 3-15 on opposite side of vehicle
- STEP 17:** Reinstall sway bar bushings and nut. (15mm wrench and factory hardware) Torque to factory specs.
- STEP 18:** Reinstall front wheels. (21mm deep well socket)
- STEP 19:** Jack up vehicle and remove jack stands. Lower vehicle to floor. Torque all bolts to factory specs.
- STEP 20:** Have alignment done to factory specifications by a certified alignment professional.

POST-INSTALLATION

- STEP 1:** Check for proper torque on all fasteners. Check steering for proper working order and check for interference. Test brake system. Check clearance between all rotating, mobile, fixed and hot parts.
- STEP 2:** Check distance between tire sidewall and the brake hose during full-turn to full-turn steering sweep. Do not skip this step! Any contact may result in component failure.
- STEP 3:** Readjust headlights to proper alignment.

MAINTENANCE: After 500 miles, re-torque all fasteners. (Recommended every 1000 miles thereafter) Have all suspension, driveline and steering components inspected by a certified technician during routine maintenance (Recommended every 3000 miles)

SOUTHERN TRUCK

Lift your life.

**2007-16 Sierra/Silverado 1500 2WD/4WD
2.5" Level Lift Kit**

15045

2 - Rear Spacer Blocks
4 - U-Bolts
8 - U-Bolt Nuts

PRE-INSTALLATION

Professional installation by a certified technician is strongly recommended.

Not responsible for altered products. No claims are made regarding any lifting devices. Any and all claims implied in this document excluded.

REQUIRED TOOLS:

Impact Wrench Floor Jack or Lift
Wrenches Jack Stands

Torque Specs:

Size	Grade 5	Grade 8	Size	Class 8.8	Class 10.9
5/16"	15 ft/lbs	20 ft/lbs	6MM	6ft/lbs	8ft/lbs
3/8"	30 ft/lbs	35 ft/lbs	8MM	16ft/lbs	22ft/lbs
7/16"	45 ft/lbs	60 ft/lbs	10MM	40ft/lbs	45ft/lbs
1/2"	65 ft/lbs	90 ft/lbs	12MM	54ft/lbs	70ft/lbs
9/16"	95 ft/lbs	130 ft/lbs	14MM	89ft/lbs	117ft/lbs
5/8"	135 ft/lbs	175 ft/lbs	16MM	132ft/lbs	175ft/lbs
3/4"	185 ft/lbs	280 ft/lbs	18MM	182ft/lbs	236ft/lbs

INSTALLATION INSTRUCTIONS

- STEP 1:** Chock front wheels and jack up rear of vehicle. Place jack stands under frame rails.
- STEP 2:** Support rear axle with jack.
- STEP 3:** Disconnect lower shock from mount.
- STEP 4:** Remove all nuts on factory U-bolts.
- STEP 5:** Remove factory U-bolts and axle mounting plate.
- STEP 6:** Lower rear axle slowly until there is enough space to install block between axle and leaf spring.
- STEP 7:** 4WD Models - Remove factory block.
- STEP 8:** Position new block and align with locating pin on leaf spring. (Tapered blocks: Narrower end faces front of vehicle)
- STEP 9:** Raise axle until block contacts leaf spring.
- STEP 10:** Install new U-bolts over saddle on leaf spring and over axle.
- STEP 11:** Re-install axle mounting plate.
- STEP 12:** Secure U-bolts with included nuts and tighten.
- STEP 13:** Re-install shock to lower mount.
- STEP 14:** Lower vehicle and torque all hardware.

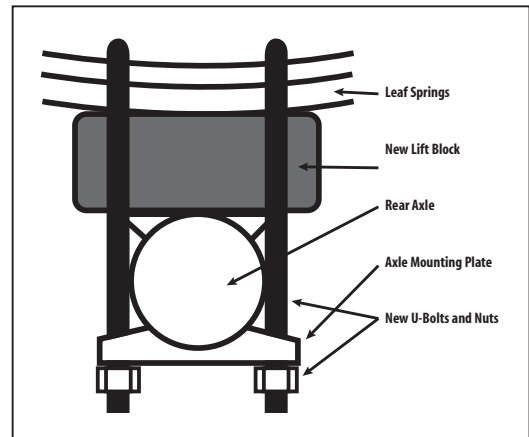

POST-INSTALLATION

- STEP 1:** Check for proper torque on all fasteners. Check steering for proper working order and check for interference. Inspect and test brake system. Check clearance between all rotating, mobile, fixed and hot parts. Check clearance between exhaust and brake lines, fuel tank and lines, wiring harness and floorboards.
- STEP 2:** Re-torque u-bolts and other fasteners after first 100 miles, then again after another 100 miles.
- STEP 3:** Adjust headlights to proper alignment.

MAINTENANCE: After 500 miles, re-torque all fasteners. (Recommended every 1000 miles thereafter) Have all suspension, driveline and steering components inspected by a certified technician during routine maintenance (Recommended every 3000 miles)