

## Ford F250/F350 Super Duty 4WD 5" Rear Block Kit

### Parts:

- 2 - Rear Spacer Blocks
- 4 - U-Bolts
- 8 - U-Bolt Nuts

## PRE-INSTALLATION

**Professional installation by a certified technician is strongly recommended.**

*Not responsible for altered products. No claims are made regarding any lifting devices. Any and all claims implied in this document excluded.*

### REQUIRED TOOLS:

Impact Wrench                      Floor Jack or Lift  
Wrenches                              Jack Stands

### Torque Specs:

| Size  | Grade 5    | Grade 8    | Size | Class 8.8 | Class 10.9 |
|-------|------------|------------|------|-----------|------------|
| 5/16" | 15 ft/lbs  | 20 ft/lbs  | 6MM  | 6ft/lbs   | 8ft/lbs    |
| 3/8"  | 30 ft/lbs  | 35 ft/lbs  | 8MM  | 16ft/lbs  | 22ft/lbs   |
| 7/16" | 45 ft/lbs  | 60 ft/lbs  | 10MM | 40ft/lbs  | 45ft/lbs   |
| 1/2"  | 65 ft/lbs  | 90 ft/lbs  | 12MM | 54ft/lbs  | 70ft/lbs   |
| 9/16" | 95 ft/lbs  | 130 ft/lbs | 14MM | 89ft/lbs  | 117ft/lbs  |
| 5/8"  | 135 ft/lbs | 175 ft/lbs | 16MM | 132ft/lbs | 175ft/lbs  |
| 3/4"  | 185 ft/lbs | 280 ft/lbs | 18MM | 182ft/lbs | 236ft/lbs  |

## INSTALLATION INSTRUCTIONS

- STEP 1:** Chock front wheels and jack up rear of vehicle. Place jack stands under frame rails.
- STEP 2:** Disconnect ABS/TC clips from U-bolts (if equipped).
- STEP 3:** Support rear axle with jack.
- STEP 4:** Remove all nuts on factory U-bolts.
- STEP 5:** Remove factory U-bolts and axle mounting plate.
- STEP 6:** Lower rear axle slowly until there is enough space to install block between axle and leaf spring. Remove factory block.
- STEP 7:** Position new block and align with locating pins on leaf spring. (Block pin toward center of vehicle)
- STEP 8:** Raise axle until block contacts leaf spring.
- STEP 9:** Install new U-bolts over saddle on leaf spring and over axle.
- STEP 10:** Re-install axle mounting plate.
- STEP 11:** Secure U-bolts with included nuts and tighten.
- STEP 12:** Lower vehicle and torque all hardware.
- STEP 13:** Re-install ABS/TC clips on U-bolts (if equipped).

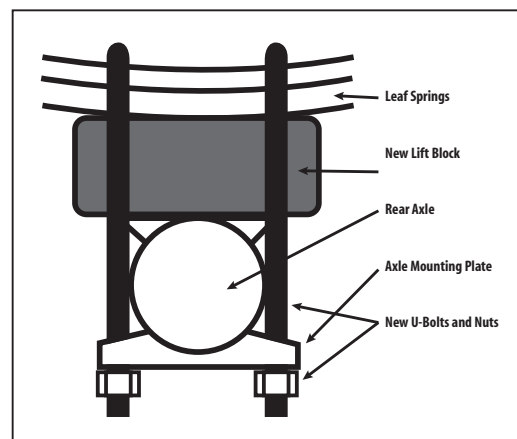

## POST-INSTALLATION

**STEP 1:** Check for proper torque on all fasteners. Check steering for proper working order and check for interference. Inspect and test brake system. Check clearance between all rotating, mobile, fixed and hot parts. Check clearance between exhaust and brake lines, fuel tank and lines, wiring harness and floorboards.

**STEP 2:** Re-torque u-bolts and other fasteners after first 100 miles, then again after another 100 miles.

**STEP 3:** Adjust headlights to proper alignment.

**MAINTENANCE:** After 500 miles, re-torque all fasteners. (Recommended every 1000 miles thereafter) Have all suspension, driveline and steering components inspected by a certified technician during routine maintenance (Recommended every 3000 miles)